

HAND OPERATED HYDROSTATIC TEST PUMP

For Testing Pipelines, Vessels, Fittings, Heat Exchangers, Sprinkler Systems, Hoses, Valves, etc.

APPLICATIONS

- Fuel Oil Transfer
- Water Well Pump
- Barrel Transfer Pump
- Manual Back up Pump
- Bilge Pump



FEATURES

- Body and Base - Close grain cast iron of ample weight to withstand the toughest conditions.
- Valves - Positive seating valves of brass or stainless steel where required for rated pressure
- Piston - Hard chrome plated steel on model HT-200. Stainless steel on all other models.
- Lever Action - Steel handle with grip designed to achieve maximum operating pressure with a minimum effort.
- Packing Gland - Bolted stuffing box allows for ease of adjustment or replacement of packing

DIMENSIONS

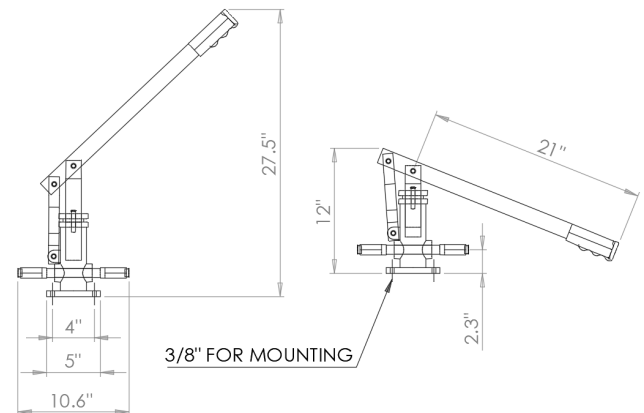

PERFORMANCE

MODEL	Max PSI	Piston Diameter	Stroke Length	Ports FNPT	Weight Lbs.
HT-200	200	1.5"	2.25"	1/2"	20
HT-500	500	1.0"	2.25"	1/2"	20
HT-1000	1000	0.75"	2.25"	1/2"	20
HT-3000	3000	0.5"	2.25"	1/2"	20
HT-5000	5000	0.375"	2.25"	1/2"	20

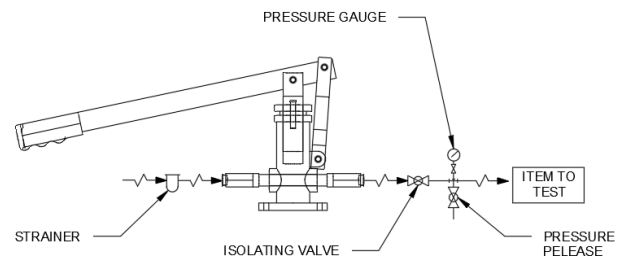

Suction lift - 7m for all sizes
For prolonged use at depth below 3m, a foot valve should be fitted.